

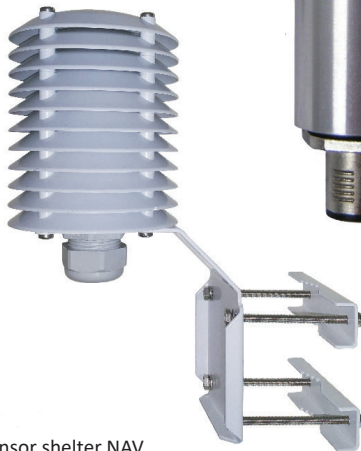

THP[pro]NAV



Sensor shelter NAV
8141.62 (optional)

THP[pro]

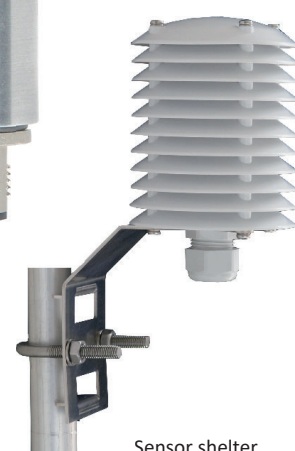

Sensor shelter
8141.6 (optional)



Features

- ▶ Combined measuring instrument for high-quality use
- ▶ Capacitive humidity measuring element
- ▶ Low maintenance
- ▶ Available protocols
RS 422/ Talker · NMEA · Modbus · SDI-12
- ▶ For use in all climatic zones
- ▶ Suitable sensor shelter optional available

Function

Proven measurement technology

The sensor THP[pro] is a combined measuring instrument for measuring relative humidity, air temperature and air pressure. The sensor is characterised by high reliability and energy-saving electronics.

If the device is handled properly the perfect function and long-term stability as well as high accuracy are ensured.



Content

1.	Warranty	2
2.	Putting into operation	2
3.	Mounting	2
4.	Electrical connection	2
5.	Connection diagram	3
6.	Installation of the sensor in the shelter	3
7.	Data protocols THP	4
8.	SDI-12 Interface	5
9.	Measurements	11
10.	Sources of error	11
11.	Maintenance and service	11
12.	Service and maintenance	12
13.	Ordering of spares	12
14.	Storage and dispatch	12
15.	Safety instructions	12
16.	Technical data	13

1. Warranty

Please note the loss of warranty and non-liability by unauthorised manipulation of the system. You need a written permission of the LAMBRECHT meteo GmbH for changes of system components. These activities must be operated by a qualified technician.

The warranty does not cover:

1. Mechanical damages caused by external impacts (e. g. icefall, rockfall, vandalism).
2. Impacts or damages caused by over-voltages or electromagnetic fields which are beyond the standards and specifications in the technical data.
3. Damages caused by improper handling, e. g. by wrong tools, incorrect installation, incorrect electrical installation (false polarity) etc.
4. Damages which are caused by using the device beyond the specified operation conditions.

2. Putting into operation

For climatic measurements the sensor should be mounted at a representative place. The sensor can be installed in any position.

The sensor must be protected against water splashes and rain. As a suitable weather and protection screen we recommend the sensor shelter (8141.6).

Dew formation and splashes do not damage the sensor, although corrupted measurement readings are recorded until all the moisture on the filter has dried up.

Inside a room you should avoid a place near heatings, windows and cold outer walls.

The protective filters should only be screwed off carefully to check functioning with the humidity standard. It is important not to touch the highly sensitive sensor element in the process.

When you screw them back on, bear in mind that sensors will not measure accurately again until they are completely dry.

3. Mounting

First of all the protective screen has to be mounted without the incorporated sensor at a selected installation place as mentioned before. When having inserted the sensor THP[pro] bottom-up into the big support of sensor shelter (8141.6), the plastic nut must be fastened carefully with a wrench.

4. Electrical connection



Incorrect voltage supplies and overloading of the outputs can destroy the sensor!

The sensor THP[pro] has to be connected with the end of the cable to an external power supply and signal evaluation (see figure opposite).

5. Connection diagram

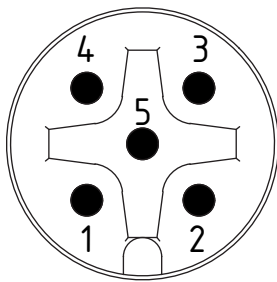
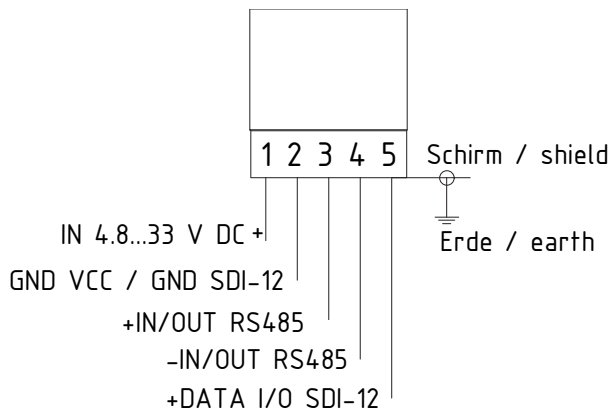

Ansicht Stiftseite
 View male side

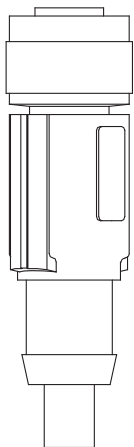

Kabel / cable
 32.05005.000500 (5m)
 32.05005.001500 (15m)

PIN	Color	Farbe
1	br	br
2	wh	ws
3	bu	bl
4	bk	sw
5	gy	gr

6. Installation of the sensor in the shelter

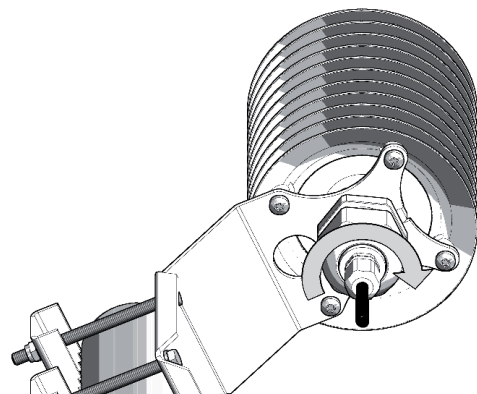
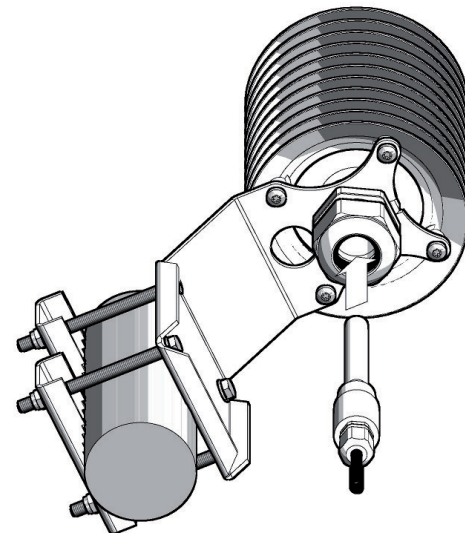
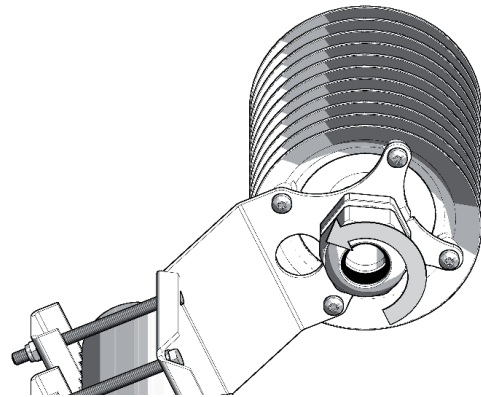



7. Data protocols THP

Message string WIMTA air temperature

Example of data sequence with comma separated

fields: \$WIMTA,-25.0,C*CS<CR><LF>

field delimiter: , (comma)

header: \$WIMTA

temperature: -40.0...+70.0

C: °C

stop limiters: <CR> <LF>

error code: 999.9

Message string WIMMB barometric pressure

Example of data sequence with comma separated

fields: \$WIMMB,,,1050.0,B*CS<CR><LF>

field delimiter: , (comma)

header: \$WIMMB

barometric pressure: 600.0...1100.0

B: air pressure in hPa

stop limiters: <CR> <LF>

error code: 9999.9

Message string WIMHU relative humidity

Example of data sequence with comma separated

fields: \$WIMHU,100.0,-40.0,C*CS<CR><LF>

field delimiter: , (comma)

header: \$WIMHU

rel. humidity: 000.0...100.0

dew point temp.: -40.0...+70.0

C: °C

stop limiters: <CR> <LF>

error code: 999.9

Important! Please note:

Field length

The development of a NMEA decoder should not be proceeded from firm field lengths. The NMEA definition proceeds from a variable field length. The comma character (",") serves as field disconnecting switch. Numeric values in a field can be presented differently. In case a field is not sent, it has a length of 0 characters (,,) [comma-comma].

Check sum

The check sum "CS" is covered to two ASCII characters hexadecimal value. "CS" calculated by XOR operation of each character in the sentence between "\$" and "*", but excluding "\$" and "*".

Error code

In case, that the sensor cannot generate a measuring value because e.g. a sensor element is defect or implausible (raw) values are collected the sensor outputs in the corresponding data protocol the above mentioned error code (e.g. 999.9) and sets the status from "A" (valid) to "V" (not valid).

Example: \$WIMWV,999.9,R,999.9,M,V*37<CR><LF>

8. SDI-12 Interface



Note: Please order the pre-configuration to SDI-12 separately by using Id-no. 97.08095.000010.

The communication using the SDI-12 protocol via the SDI-12 interface is based on the "SDI-12 A Serial-Digital Interface Standard for Microprocessor-Based Sensors, Version 1.3, 2016". The TH/THP[pro] sensor can be used in bus operation parallel to other sensors with SDI-12 data protocol.

The following subset of SDI-12 commands is implemented in the TH/THP[pro] sensor. For further information about the SDI-12 protocol please refer to the previously mentioned standard documentation or to the website www.SDI-12.org.

Implemented SDI-12 commands:

Command	Function	Sensor response
a!	Acknowledge active	a<CR><LF>
?!	Address query	a<CR><LF>
a!	Send identification	allccccccmmmmmmvvvxx...xx<CR><LF>
aAb!	Change address	b<CR><LF>
aM!	Start measurement	atttn<CR><LF>
aMC!	Start measurement and request CRC	atttn<CR><LF>
aC!	Start concurrent measurement	atttnn<CR><LF>
aCC!	Start concurrent measurement and request CRC	atttnn<CR><LF>
aD0!	Send data (buffer 0)	a<Werte><CR><LF>
aD1!	Send data (buffer 1)	a<Werte><CRC><CR><LF>
aD2!	Send data (buffer 1)	a<Werte><CRC><CR><LF>
aV!	Start verification	atttn<CR><LF>

a = address of the corresponding sensor; standard sensor address = 0

SDI-12 commands always start with the address of the corresponding sensor. Thus all other sensors on the same bus ignore commands that do not match their own address. SDI-12 commands end with a "! All sensor responses also start with the address (shown below with "a") of the sensor and always end with the ASCII characters "Carriage Return" "<CR>" and "Line Feed" "<LF>".

The SDI-12 protocol is based on the ASCII character set. The baud rate is 1200 Baud and has the byte frame format:

- 1 start bit
- 7 data bits (least significant bit first)
- 1 parity bit (even parity)
- 1 stop bit

Acknowledge active – (a!)

This command ensures that the sensor responds to requests. In general, it requests the sensor to confirm that it is connected to the bus. The sensor returns its address and the characters <CR><LF>.

Command: **a!** (Acknowledge active)
Response: **a<CR><LF>**

Example:

Command	Response
0!	0<CR><LF>
1!	1<CR><LF>



Send identification – (aI!)

Provides sensor-specific information such as model number, firmware version, etc.

Command: **aI!** (I – Command „Send identification“)
 Response: **a13LMGmbH1508095x310871202.0001<CR><LF>**
 | | | | **871202.0001** – (11 characters) serial number TH/THP
 | | | | **310** – (3 characters) sensor firmware version (= version 3.10)
 | | **08095x** – (6 characters) sensor type (x: T = TH[pro], P = THP[pro])
 | **LMGmbH15** – (8 characters) manufacturer name (= Lambrecht meteo GmbH)
13 – (2 characters) SDI-12 - version (13 = version 1.3)

Example:

Command	Response
0I!	013LMGmbH1508095T310871202.0001<CR><LF> (TH[pro])
1I!	113LMGmbH1508095P310871202.0001<CR><LF> (THP[pro])

Change address – (aAb!)

The factory setting for the address is "0". If several sensors are connected to the same bus, the sensor address can be changed with the command **aAb!**. The address is always a single ASCII character. By default, the ASCII characters are used for the numbers between "0" to "9" (decimal 48 to 57). If more than 10 sensors are connected to one bus, the characters "A" to "Z" (decimal 65 to 90) as well as "a" to "z" (decimal 97 to 122) can be used alternatively. The sensor responds with its new address and **<CR><LF>**. After the address has been changed, no further commands should be sent to the sensor for about one second (see also "SDI-12 Standard, Version 1.3, 2016").

Command: **aAb!** **A** – function "change address", **b** – new sensor address
 Response: **b<CR><LF>** **b** – response with new sensor address

Example:

Command	Response
0A1!	1<CR><LF>

Start measurement – (aM!)

The command **aM!** requests the sensor to process the available measurement data and to record it in an output string. Unlike the standard sensors as described in the SDI-12 documentation, the TH/THP[pro] sensor measures continuously. The data can be retrieved with the corresponding commands "**aD0!**" to "**aD2!**". The data is saved until the next "**C**", "**M**" or "**V**" command and can be retrieved several times.

Command: **aM!** **M** – function "start measurement"
 Response: **a0004<CR><LF>** (TH[pro]) / **a0005<CR><LF>** (THP[pro])
 | |
 | **4 or 5** – number of measured values (air pressure only THP [pro])
000 – seconds until the sensor returns the measured data (000 = immediate query possible)

Example:

Command	Response
1M!	10005<CR><LF>

The measurement data can then be retrieved with the commands **aD0!**, **aD1!** and **aD2!** (see below under "Send data").

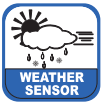

Start measurement and request CRC – (aMC!)

Same command as "aM!", but in addition to the processed measurement data, the sensor sends a 3-digit CRC checksum. For further information on generating this CRC checksum please refer to "SDI-12 Standard, Version 1.3, 2016, Chapter 4.4.12".

Command: **aMC!** **M** – command "start measurement", **C** – request CRC checksum
 Response: **a0004<CR><LF>** (TH[pro]) / **a0005<CR><LF>** (THP[pro])
 | |
 | **4 or 5** – number of measured values (air pressure only THP [pro])
000 – seconds until the sensor returns the measured data (000 = immediate query possible)

Example: Command Response
1MC! **10005<CR><LF>**

Start concurrent measurement – (aC!)

With "concurrent measurement", the data logger can measure concurrently with several TH/THP[pro] sensors connected to the same bus. The command "aC!" requests the sensor to process the available measurement data and record them in an output string. Unlike the standard sensors, as described in the SDI-12 documentation, the TH/THP[pro] measures continuously. The data can be retrieved with the corresponding commands "aD0!" to "aD2!". The data is saved until the next "C", "M", or "V" command and can be retrieved several times.

Command: **aC!** **C** – command "start concurrent measurement"
 Response: **a00016<CR><LF>** (TH[pro]) / **a00020<CR><LF>** (THP[pro])
 | |
 | **16 or 20** – number of measured values (20 measured values with air pressure only THP[pro])
000 – seconds until the sensor returns the measured data (000 = immediate query possible)

Beispiel: Befehl Antwort
1C! **100020<CR><LF>**

The measurement data can then be retrieved with the commands **aD0!**, **aD1!** and **aD2!** (see below under "Send data").

Start concurrent measurement and request CRC – (aCC!)

Same command as "aC!", but in addition to the processed measurement data, the sensor also sends a 3-digit CRC checksum. For further information on generating this CRC checksum please refer to "SDI-12 Standard, Version 1.3, 2016, Chapter 4.4.12".

Command: **aCC!** **C** – command "start concurrent measurement", **C** – request CRC checksum
 Response: **a00016<CR><LF>** (TH[pro]) / **a00020<CR><LF>** (THP[pro])
 | |
 | **16 or 20** – number of measured values (20 measured values with air pressure only THP[pro])
000 – seconds until the sensor returns the measured data (000 = immediate query possible)

Example: Command Response
1C! **100020<CR><LF>**

The measurement data can then be retrieved with the commands **aD0!**, **aD1!** and **aD2!** (see below under "Send data").



Send data – (aD0!), (aD0!), (aD1!)

The data requested from the sensor with the commands "C" or "M" can be retrieved with the commands "aD0!", "aD1!" and "aD2!". The sensor uses the corresponding characters ("+" or "-") as field separators. If the data were requested with a "CC" or "MC" command, a CRC checksum will also be returned. For further information on generating this CRC checksum please refer to "SDI-12 Standard, Version 1.3, 2016, Chapter 4.4.12". The output of the measured data is in metric units.

Up to a maximum of 20 measured values can be retrieved from the output telegrams aD0!, aD1! and aD2!. The period "from retrieval to retrieval" is limited to max. 70 minutes. Afterwards, average and min/max values are reset and a new time period is automatically started.

If **erroneous data** have been generated during the measurement or if the function of the sensor is permanently disturbed, the corresponding measured data are output with the "sensor error value" **-999.9**. This identification is unambiguous and lies far outside the real measuring range.

Example (error codes):

Command: 1CC! and following query of block 1 of the measured data with 1D0!
Response: 1-999.9-999.9-999.9-999.9-999.9-999.9-999.9GGi<CR><LF>

Data and retrieval description

THP[pro] (20 measured values)

Value No.	Measured values	Range / Formats	Unit
1	Air temperature Instantaneous value	-40.0...+70.0	°C
2	Minimum (from retrieval to retrieval)		
3	Maximum (from retrieval to retrieval)		
4	Mean value (from retrieval to retrieval)		
5	Relative humidity Instantaneous value	+0.0...+100.0	%
6	Minimum (from retrieval to retrieval)		
7	Maximum (from retrieval to retrieval)		
8	Mean value (from retrieval to retrieval)		
9	Dew point Instantaneous value	-40.0...+70.0	°C
10	Minimum (from retrieval to retrieval)		
11	Maximum (from retrieval to retrieval)		
12	Mean value (from retrieval to retrieval)		
13	Air pressure Instantaneous value	+600.0...+1100.0	hPa
14	Minimum (from retrieval to retrieval)		
15	Maximum (from retrieval to retrieval)		
16	Mean value (from retrieval to retrieval)		
17	Absolute humidity Instantaneous value	+0.0...+200.0	g/m ³
18	Minimum (from retrieval to retrieval)		
19	Maximum (from retrieval to retrieval)		
20	Mean value (from retrieval to retrieval)		

Table 1



THP[pro] - Output of measured data when queried with aM! or aMC! (with CRC checksum)

Command: **aM!** (aM! = buffering instantaneous values for output)
 Response: **10005<CR><LF>** (5 measured values are available for retrieval without delay)

Command: **aD0!** (retrieve measured values from buffer memory)

Response: **a+22.5+41.2+8.7+976.0+8.2<CR><LF>016<CR><LF>**
 | | | | |
 | | | | **+8.2** – absolute humidity (value no. 5)
 | | | **+976.0** – air pressure (value no. 4)
 | | **+8.7** – dew point (value no. 3)
 | **+41.2** – relative humidity (value no. 2)
+22.5 – air temperature (value no. 1)

Example: Command **1MC!** Response **1+22.2+39.6+7.8+975.1+7.7KNJ<CR><LF>**

THP[pro] - Output of measured data when queried with aC! or aCC! (with CRC checksum)

Command: **aC!** (aC! = buffering all available values for output)
 Response: **100020<CR><LF>** (20 measured values are available for retrieval without delay)

Note: Due to the length limitation to max. 75 bytes, the data are split into 3 data sets!

Command: **aD0!** (aD0! = call up measured values 1 to 8 from **buffer memory 1**)

Response: **1+22.3+22.2+22.4+22.2+37.6+36.0+37.6+36.8<CR><LF>**
 | | | | | | | |
 | | | | | | | **+36.8** – relative humidity, mean value (value no. 8)
 | | | | | | **+37.6** – relative humidity, maximum (value no. 7)
 | | | | | **+36.0** – relative humidity, minimum (value no. 6)
 | | | | **+37.6** – relative humidity, instantaneous value (value no. 5)
 | | | **+22.2** – air temperature, mean value (value no. 4)
 | | **+22.4** – air temperature, maximum (value no. 3)
 | **+22.2** – air temperature, minimum (value no. 2)
+22.3 – air temperature, instantaneous value (value no. 1)

Command: **aD1!** (aD1! = call up measured values 9 to 16 from **buffer memory 2**)

Response: **1+7.2+6.5+7.2+6.8+978.5+978.4+978.8+978.5<CR><LF>**
 | | | | | | | |
 | | | | | | | **+36.8** – air pressure, mean value (value no. 16)
 | | | | | | **+37.6** – air pressure, maximum (value no. 15)
 | | | | | **+36.0** – air pressure, minimum (value no. 14)
 | | | | **+37.6** – air pressure, instantaneous value (value no. 13)
 | | | **+6.8** – dew point, mean value (value no. 12)
 | | **+7.2** – dew point, maximum (value no. 11)
 | **+6.5** – dew point, minimum (value no. 10)
+7.2 – dew point, instantaneous value (value no. 9)



Command: **aD2!** (aD2! = call up measured values 17 to 20 from **buffer memory 3**)

Response: **1+7.4+7.1+7.4+7.2<CR><LF>**

				+6.7 – absolute humidity, mean value (value no. 20)
				+7.2 – absolute humidity, maximum (value no.19)
				+6.5 – absolute humidity, minimum (value no. 18)
				+7.2 – absolute humidity, instantaneous value (value no. 17)

Start verification – (aV!)

For compatibility reasons, the command "**aV!**" is used to provide extended information if necessary later. The response is always "+1".

Command: **aV!** (Acknowledge active)

Response: **a<CR><LF>**

Example:	Command	Response
	1V!	1+1<CR><LF>

Note on SDI standard commands

In terms of protocol, TH/THP[pro] support the standard command set (see "SDI-12 A Serial-Digital Interface Standard for Microprocessor-Based Sensors, version 1.3, 2016", page 7, chapter 4.4 and table 5).

The sensors respond to all commands with a valid data transfer. The information content of unsupported commands is reduced to pure protocol sequence control, i.e. there is no further activity for these requests (e.g. aD3! etc.) due to the responses sent.

9. Measurements

The measuring probe is adjusted by delivery. For putting into operating another readjustment is not required. The probe is ready for use one second after being switched on and sends its first data protocol.



Before a reliable measurement can be made, the measuring probe and medium to be measured must be in temperature and humidity equilibrium.

The necessary adjustment time, which can last up to 30 minutes, depends upon several factors:

- Size of the humidity and temperature deviation of probe and medium before start of measurement
- Change of the measured values during the adjustment time.

The humidity measurement delivers a better picture of the progress of acclimatization since it reacts much more quickly and more sensitively than the temperature measurement. The 1/10 percent display is therefore very suitable as a trend display. If the display oscillates about mean value, then adjustment is completed.

10. Sources of error

Humidity measurements are very sensitive to various influences:

- **Temperature errors**
due to too short adjustment time, sunshine during the measurement, heating, cold outer wall, air draft (e.g. fans), radiating hand and/or body heat etc..
- **Humidity errors**
due to steam, water splashes dripping water or condensation on the sensor etc.. Repeatability and long-term stability in operation are not impaired by this even if the probe has been exposed to high humidity or saturation with water vapor over a lengthy period.
- **Contamination**
of the humidity sensor can be largely avoided by using a corresponding filter. The filters must be cleaned or replaced periodically depending upon the degree of contamination of the measuring site.



The sensor is insensitive to chemicals, when they occur in normal concentrations (MAK values = maximum workplace exposure). At higher concentrations or possibilities of contact with liquid chemicals, the manufacturer must always be consulted!

11. Maintenance and service

Definitions

Calibration = Control measurement with a humidity standard.

Adjustment = Calibration + additional readjustment of the probe to the setpoint value.

Temperature

The probe is adjusted before delivery. A temperature readjustment is normally not required. In case of doubt please contact the producer.

Humidity

The probe is adjusted before delivery so that the results are in optimum accuracy over the full measuring range.

We recommend you to **check the probe at least once a year.**



Please only use the original humidity standards for this.

The humidity standards are not normally dangerous to humans, but can irritate sensitive skin. In the case of contact with the skin or the eyes, the solution must be washed out immediately and thoroughly with plenty of water. The humidity standards must not be consumed!

The calibration device for calibration and adjustment and the required humidity standards are obtainable as an accessory.

Cleaning

Contaminated filters can cause measuring errors and prolong the adjustment time. Depending upon the degree of contamination of the filter, this must be cleaned or if necessary replaced periodically.



In order not to damage the sensors, unscrew the filter for cleaning.

Clean the filter with soapy water, alcohol or a cleaning agent suitable for removing contamination and rinse thoroughly with water.

Do not screw the filter back onto the probe until it is completely dry.



The fault tracing and service work only should be carried out by a skilled technician having passed a factory training at our facilities or a similar course.

12. Service and maintenance

Periodical visual checks

The producer recommends periodical visual checks of the sensor and shelter housing regarding outer damages, watertightness and the fixing of the mounting screws, at intervals of four weeks.

Change of spare parts

All spare parts or alternate devices can be replaced with regular tools such as wrenches, screw drivers etc.

Accessories and spare parts list

No.	Description	Id-No.
1.	Sensor shelter For the protection of the sensor against influences of radiation, wind and temperature as well as for mounting at a mast.	00.08141.600000
2.	Cable 15 m	32.14567.060010
3.	Membrane filter as sensor protection	37.08093.100001
	<u>alternative:</u> Sinter filter as sensor protection	37.08095.100001

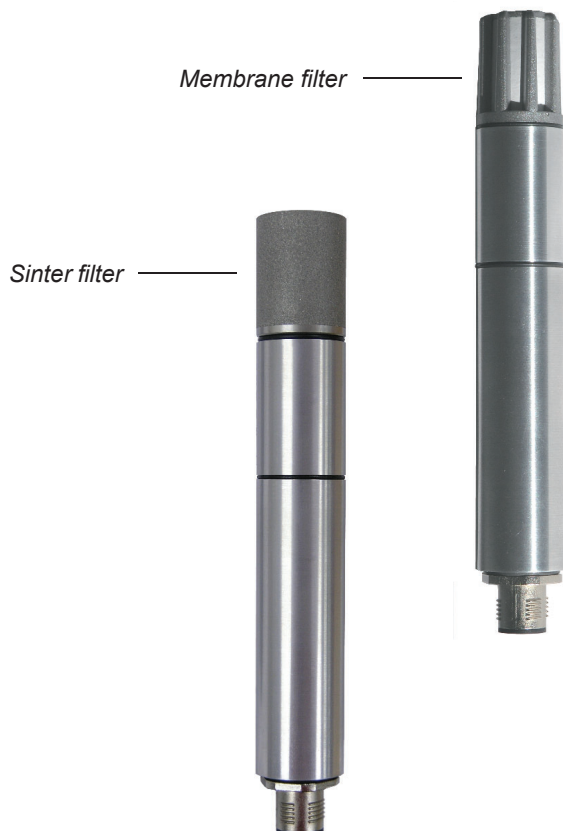

13. Ordering of spares

The following information are required for a rapid and accurate exchange or replacement of the components:

- Name of item and type number
- Ordering number/parts number
- Required quantity

Optional (if available):

- Names of related or connected components
- Type of vessel and country of origin
- Reference number of LAMBRECHT wiring diagram designated with the bold letters SKF... or SWF... and a 3- or 4-digits running number.

Above mentioned data can be obtained from the designation label, from the spares list of this system component or from the order specific documentations.

14. Storage and dispatch

The sensor should be stored in a clean and dust-free area between -40...+70 °C (not condensing) in a cardboard box or similar container.

Alternative packing material should be adequate to the standard of the original packing of LAMBRECHT. It must ensure an optimal protection against mechanical or electrical influences as well as against other transport damages caused by liquids or by the weather.

15. Safety instructions

This system is designed according to the state-of-the-art accepted safety regulations. However, please note the following rules:

1. Before set into operation, please read all appropriate manuals!
2. Please take notice of internal and state-specific guidelines and/or rules for the prevention of accidents (e.g. the professional association). If necessary ask your responsible safety representative.
3. Use the system according to the manual's regulations only.
4. Always leave the manual at hand at the place of work of the system.
5. Use the system in technically correct conditions only! You have to eliminate influences immediately, which impair the security .
6. Prevent the ingress of liquids into the devices .
7. Make sure that the system is free of power before cleaning of the devices. Do not use noxious or flammable detergents.

16. Technical data

	THP[pro] Sensor · THP[pro]NAV Sensor
Temperature	
Measuring range:	-40...+70 °C
Resolution:	0.1 °C
Improved accuracy:	± 0.1 K (0...60 °C) • ± 0.2 K (-40...0 °C) ¹⁾
Relative humidity	
Measuring range:	0...100 % r. h.
Resolution:	0.1 % r. h.
Improved accuracy:	typ. ± 1.5 % (0...80 %) r. h. • ± 2 % (> 80 %) r. h. ¹⁾ • Reaction time rel. humidity (at v = 1.5 m/s): 30 s ²⁾
Barometric pressure	
Measuring range/Resolution:	500...1100 hPa • 0.1 hPa
Accuracy:	± 2 hPa (at -30...+70 °C) • ± 1 hPa (at -10...+60 °C) • ± 0.5 hPa (at 25 °C)
Further technical data	
Supply voltage:	4.8...33 VDC
Current consumption ³⁾ :	4 mA at 24 VDC • 6 mA at 12 VDC • 11 mA at 4.8 VDC
Housing:	Aluminium especially-coated • IP 65 (housing) • M12 plug connector (4-pole)
Weight/Dimensions:	approx. 80 g • H 140 mm x Ø 20 mm
Interface:	Serial RS 422/ Talker • Baudrate 4800 • 1 Hz • 8N1 • SDI-12 [*])
Protocols:	NMEA 0183 • WIMHU • WIMMB • WIMTA
Accessories: (please order separately)	Sensor shelters: 00.08141.600000 · with natural ventilation 00.08141.600004 · with artificial ventilation
*) Option: (please order separately)	Service: 97.08095.000010 · Pre-configuration of the standard THP[pro] to SDI-12

¹⁾ ventilated sensor shelter recommended ²⁾ with filter membrane ³⁾ without terminating resistor

Dimensional drawing

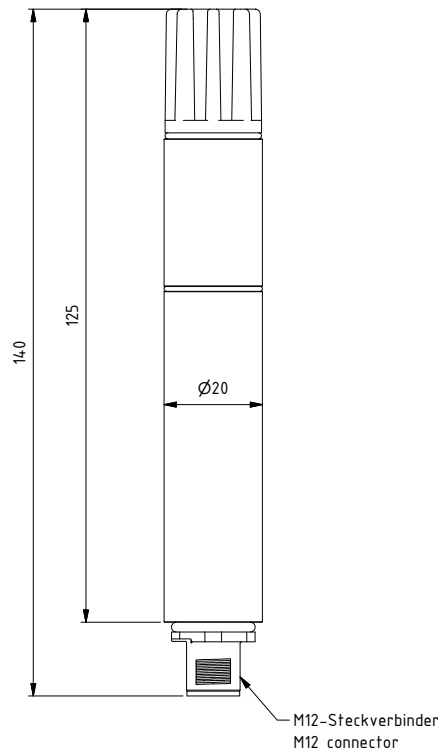

Versions available

Id No.	Type
00.08095.100030	THP[pro]Modbus [*])
00.08095.100031	TH[pro]Modbus [*])
00.08095.101000	THP[pro]NAV
00.08095.101001	TH[pro]NAV [*])
00.08095.100000	THP[pro]
00.08095.100001	TH[pro] [*])

^{*}) separate manual

Subject to change without notice.

8095_THP_pro_b-de.indd 13.20