

Insulation Guard IW1000



- Time optimized pulse measuring method
- 2 alarm outputs relay, 1 analogue output
- Automatic and manual self test
- Acoustic alarm in case of malfunction
- Devices for railway vehicles and healthcare facilities available

Characteristics

The isolation-guard IW1000 will be used for insulation-monitoring in machines and systems with ungrounded voltage systems. The universal design allows the monitoring of all AC - and DC -Systems.

Common informations

In well-insulated IT-systems (new installations) with a lot of connected devices a high leakage capacity may occur due grounded input filters, cable capacities etc. Common insulation guards, working with pulse measuring mode, are running with fixed pulse widths. For well operation, they must be adapted manually to the actual leakage capacity of the system. There are also insulation guards available, working with self adapting pulse width. However these devices need a long measuring time because the result will be at least available, when loading voltage will find its maximum (no more change in load voltage). With the time optimized measuring method of the IW1000, insulation resistance and leakage capacity will be calculated after 2-time constants. Therefore the reaction time of the IW1000 is very short. By applications of modern signal processing-algorithms in the software and over sampling-mode in connection with high signal-dissolution of the AD-converter, the IW1000 runs with high stability and reliable measurement.

Comparison of the DC-measuring procedure with the time optimized pulse measuring procedure of the IW1000

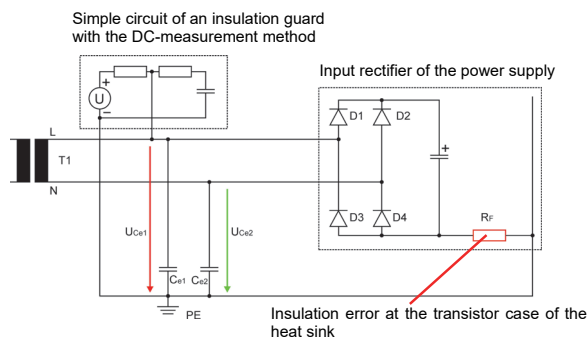

DC-components of the leakage currents could appear without insulation error in case of an asymmetric load during positive and negative half-waves. For example: Power controlled devices which are operating in phase-angle control or as zero-crossing switch (SSR- relays). Even frequency converters produce high DC-leakage currents. With time optimized pulse measuring method of the IW1000, DC-voltage-shares at the leakage capacities measured during positive and negative voltage pulses will be eliminated automatically by calculation. Therefore the measuring method is qualified for AC-AC/DC and true DC-systems.

Connection examples

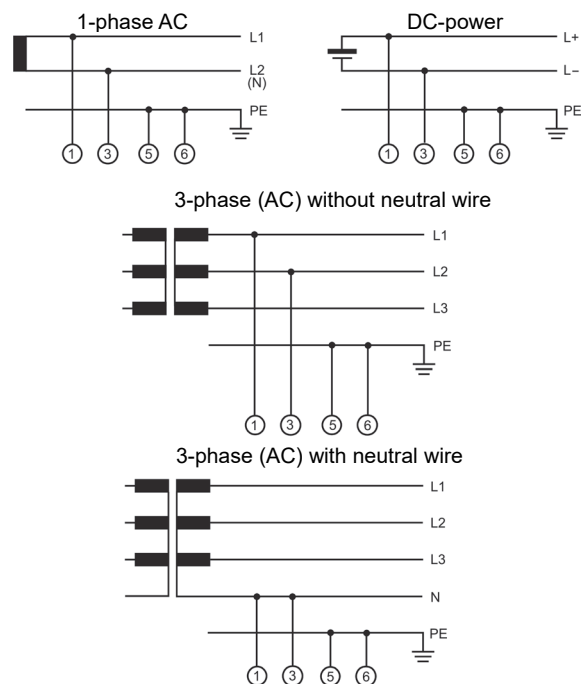

Characteristic curve 1, measuring time

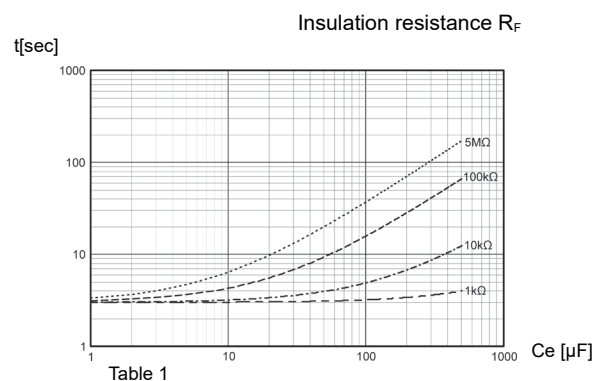

Technical data
Power supply

 Supply voltage : 230 V AC, 115 V AC, 24 V AC $\pm 10\%$;
 16.8..33.6 V DC, 10.8..15.6 V DC

 Power consumption: max. 4 VA
 Operating temp. : -10..+55 °C;

Option 01 : -25..+70 °C

 Relative humidity : 75 % for annual mean in accordance with
 DIN EN50155, 95 % for 30 days all year
 continuously, seldom or low humidity doesn't
 lead to malfunctions or cancellations.

 CE-conformity : EN 60664-1, EN 61326-2-4, EN 50121-3-2,
 EN 60068-2-1/2/6/27

 add. for Option 01 : EN 50155 in following points: EN 61373,
 EN 60068-2-27

 Fire safety : Fulfilment of fire safety requirements for
 railway vehicles acc. to the basic standard
 NFF16-101 particularly (IEC) EN 60695-2-12
 (Glow-wire testing temperature 850 °C) and
 NFF16-102 particularly 6.2; 6.4; 6.5

Input

 U_{nom} : 0..690 V AC/DC; ab UN >400 V
 operation only with cover clamp permitted

 Frequency range : 16^{2/3}..400 Hz

Measurement (standard) (health care)

 U_{meas} max. : ± 40 V ± 20 V
 I_{meas} max. : ± 220 μ A ± 110 μ A
 Ri DC : 180 k Ω (2 x 360 k Ω parallel)
 Impedance Zi : 180 k Ω (2 x 360 k Ω parallel) at 50 Hz

Operating values

 AL1/AL2 : 1 k Ω ..5 M Ω x 1,1 (1,1 k Ω ..5,5 M Ω)
 programmable

 Accuracy : $\pm 5\%$, ± 1 k Ω in the range 1 k Ω ..5 M Ω

Hysteresis : 10..100 % of the setpoint programmable

Measuring time : see table1

System leakage

 capacity : max. 500 μ F

Display : LCD Dot-Matrix, 2 lines 8 characters each,
 character height 5 mm, with back light

 Indicating range : 1 k Ω ..9.9 M Ω

 Solution : 1 M Ω ..9.9 M Ω : 0.1 M Ω

 1 k Ω ..999 k Ω : 1 k Ω
Output

 Relay SPDT : < 250 V AC < 250 VA < 5 A;
 < 300 V DC < 50 W < 2 A

 Analogue : 0..1 mA, R_F (Insulation resistance)

Case : Makrolon 8020 UL94V-1

Weight : approx. 390 g

 Connection : screw terminals 4 mm²

Protection class : case IP40, terminals IP20, BGV A3

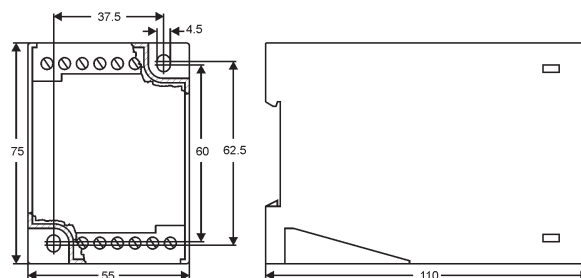
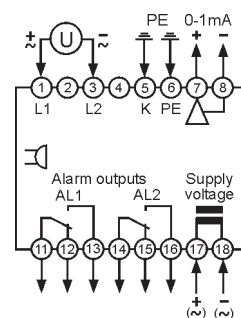
Dimensions

Connection diagram

Ordering code

 IW1000 - - - -

1. Model	
1	2 inputs L1 + L2 , output 0..1 mA for ext. pointer instruments
3	as 1, for health care facilities
2. Supply voltage	
0	230 V AC $\pm 10\%$ 50-60Hz
1	115 V AC $\pm 10\%$ 50-60Hz
4	24 V AC $\pm 10\%$ 50-60Hz
5	24 V DC 16.6..33.6 V DC
6	12 V DC 10.8..15.6 V DC
3. Options	
00	without option
01	device for rail vehicles
02	measuring time 1 s C _{E,max} < 200 μ F)
4. Additional text above the display (3x50 mm HxW)	
Accessories	
KA-IW1000-1	terminal cover for U _{meas} > 400 V
IS96-DS-01	pointer instrument DIN 96x96 mm, mounting depth 63mm

Pointer instrument IS96

