

Product information

Temperature Measuring Transducer TC125



- Universal input for Pt100, Pt1000, thermocouple J / K / S
- Thermocouples with temperature compensation that can be switched off
- Development conforms to EN 61508
- Available with intrinsically safe inputs, type of protection ia, Zone 0/20
- 24 pre-scalings that can be adjusted using trimmer potentiometers
- Analog output 0 (4) .. 20 mA and 0 / (2)..10 V, simultaneously
- Wide range AC / DC or 24 V DC supply
- Optional auxiliary voltage supply via DIN rail bus

Characteristics

The TC125 temperature transmitters convert signal of temperature resistance (Pt100 / Pt1000) or thermocouples (J, K, S) into standard signals (0 / 4..20 mA and 0 / 2..10 V).

Applications with signals from the Ex area or requirements of higher environmental immunity, require galvanic isolation. This applies especially to grounded temperature sensors.

The TC125 therefore has a 3-way electrical isolation between input, output and auxiliary voltage. PT100, Pt1000 and thermocouples have 8 preconfigured measuring ranges available. With trim potentiometers in the front, zero point and range can be adjusted easily. When using thermocouples, an internal temperature compensation - by measuring the terminal temperature - can be activate or deactivate.

With an intrinsically safe input (EX) the use in Ex-applications is possible.

Measurement inputs

The following measuring ranges can be configured via DIP switches and adaptable with a trim potentiometer.

Measuring ranges resistance thermometer	
Pt100	Pt1000
-50..50 °C	-50..50 °C
0..50 °C	-30..70 °C
0..100 °C	-20..40 °C
0..150 °C	0..50 °C
0..200 °C	0..100 °C
0..300 °C	0..150 °C
0..500 °C	0..200 °C
0..850 °C	0..250 °C

Measuring ranges thermocouple		
Type J (FeCuNi)	Type K (NiCrNi)	Type S (PtRhPt)
0..250 °C	-50..250 °C	0..1500 °C
0..500 °C	0..500 °C	
	0..750 °C	
	0..1000 °C	
	0..1250 °C	

Technical data

Explosion protection

Ignition protection typ ia	Intrinsically safe Inputs
Type	: TC125L-Ex / TC125LP-Ex / TC125M-Ex
Zone 0/1/2	: II (1) G [Ex ia Ga] IIC
Zone 20/21/22	: II (1) D [Ex ia Da] IIIC

Ignition protection typ ic	Intrinsically safe Inputs + Zone 2 installation
Type	: TC125L-Ex / TC125LP-Ex
Zone 2	: II 3 G Ex ec [ic] IIB T4 Gc

Limit values	
Intrinsically safe circuit	U _o = 2,2V; I _o = 4,2mA; P _o = 2,4mW C _i = 33nF; L _i ≈ 0mH C _o = 10,9uF with L _o = 50mH

Ignition protection typ ec	Without intrinsically safe Inputs, Zone 2 installation
Type	: TC125L / TC125LP
Zone 2	: II 3 G Ex ec IIB T4 Gc

Auxiliary voltage	
TC125M	: 85..250 V AC(47..63Hz), <1,5 W, <3 VA
(Wide-range power supply)	20..125 V DC, < 1,5W
TC125L/LP	: 24 V DC +/-15 %, < 1,5 W
(DC and Power Rail)	

Product information

Temperature

Combined data

CE conformity

Low-voltage directive	: 2014/35/EU : EN 61010-1
	EN 60664-1
EMC	: 2014/30/EU : EN 61326-1
ATEX	: 2014/34/EU : EN 60079-0
	EN 60079-11
	EN 60079-7

Rated voltage	:
EN 60664-1	: 250 V AC, overvoltage category 2, degree of contamination II
EN 60079-11	: 250 V AC / 125 V DC
Test voltage	: 3kV AC between supply / input / output
Ambient temperature	: -10..60 °C
Storage temperature	: -20..80 °C
Relative air humidity	: 10..90 % (no condensation)

Input

Accuracy

Standard error	: 0,2 %
Linearity error	: 0,05 %
Temperature coefficient	: 0,01 %/K
Output current / voltage	: 0,1 %

Resistance temperature sensor

Input circuit	: 3-wire-compensation, (2-wire connection with elect. bridge)
Line resistance	: 100 Ohm, max. (integration of safety barriers possible)
Break of sensor detection:	yes
Short circuit detection	: yes

Pt100

Measuring current	: approx. 1 mA
Detection range	: -70..+850 °C
Zeropoint adjustment	: approx. +/-8 Ohm (approx. +/-20 °C)
End-value adjustment	: approx. +/- 15 % of factory end value

Pt1000

Measuring current	: approx. 100 µA
Detection range	: -70..+260 °C
Zeropoint adjustment	: approx. +/- 80 Ohm (approx. +/- 20 °C)
End-value adjustment	: approx. +/- 15 % of factory end value

Thermocouple

Cold junction compensation:	yes, selectable
Break of sensor detection:	yes
Detection range	: J, Fe-CuNi: -70..+900 °C
	K, NiCr-Ni: -100..+1250 °C
	S, PtRh-Pt90/10: 0..1800 °C
Zeropoint adjustment	: approx. +/- 10 % of factory end value
End-value adjustment	: approx. +/- 15 % of factory end value

Analogue outputs

0/2..10 V	: switchable, load <5 mA, short circuit proof
0/4..20 mA	: switchable, burden <600 Ohm, simultaneous use with voltage output possible

Behavior in case of error

Standard	: 0 mA; 0 V (downscaling)
Option 02	: >21 mA; > 10,5 V (upscaling)

Transmission path

Step response T90	: <800 msec
-------------------	-------------

Housing

Dimensions (W x D x H)	: 12,5 x 114 x 108 mm
Material	: Polyamid (PA) 6.6, light grey, flammability class V0 (UL94)
Weight	: 120 g
Protection class	: IP20
Screw terminals	: 0,2..2,5 mm ² , AWG 24..14, removable encoded
Push-In terminals	: 0,5..1,5 mm ² , AWG 25..16, (spring clamps) double connection (12A between the connectors), removable encoded
Power Rail	: 8A over entire bus system (supply via removable terminals 0,2..2,5 mm ² , AWG 24..14)

Dimensions

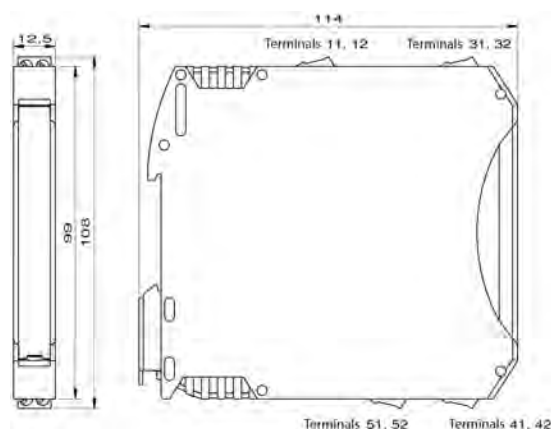

Connection diagram

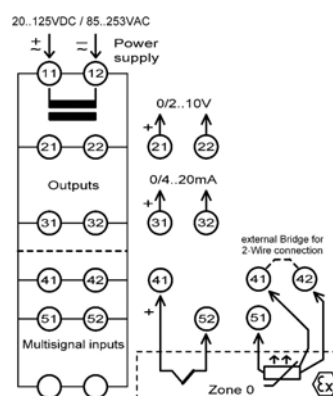

Product information
Order code

1. 2. 3. 4.

- - -

1. Device version	
TC125L	Supply voltage 24 V DC +/- 15%
TC125LP	Supply voltage 24 V DC +/- 15% Powerrail supply, including rail bus connector
TC125M	Wide-range supply 20..125 V DC / 85..253 V AC
2. Explosion protection	
00*	Installation of devices type TC125 in zone 2, acc. to ATEX ignition protection typ "ec" possible
Ex	In case of installing the devices out of the ex-zone: Input and transmitter feed are intrinsically safe in accordance to ignition protection type "ia" for zones 0 and 20. The devices types TC125L and TC125LP may be installed in zone 2 according to ATEX-ignition protection type „ic
3. Options	
00	Without option
01	Push-In terminals (pluggable)
02	Upscaling output behavior, error state > 21mA, > 10,5V (Standard: Downscaling, output 0mA, 0V)

*) TC125L / LP-00 may be installed in Zone 2 according to ATEX type of protection "ec". This requires installation in a clean environment in a conductive, earthed housing (control cabinet) with a minimum of IP54 protection.

**) Type of protection permitted when installing the devices outside the Ex area. TC125L / LP-Ex may be installed in Zone 2 according to ATEX type of protection "ic".