

Product information

Transmitter / Signal Conditioning

Universal Transmitter MU500



Dimensions

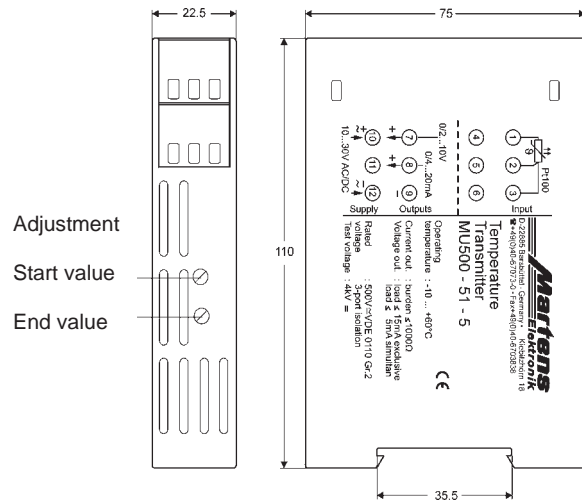

Characteristics

Temperature transmitter MU500 accept field signals of Pt100 or Pt1000 RTD sensors to the input which is filtered, isolated and converted into industry standard signals for process control systems. The multipurpose design of inputs and outputs, also the wide range of the supply voltage reduces the number of types. The small case allows space-saving mounting.

Technical data

Power supply
Supply voltage : 85..265 V AC/110..125 V DC or 10..30 V AC/10..42 V DC
Frequency AC : 40..400 Hz
Power consumption : max. 2.2 W , max. 3.3 VA
Operating temperature : -10..+60 °C
CE-conformity : EN 61326-1:2013; EN 60664-1:2007

Input
RTD Pt100 : 13 ranges, switch selectable
- Sensor current : Pt100 approx. 1 mA
RTD Pt1000 : 16 ranges, switch selectable
- Sensor current : Pt1000 approx. 0.25 mA
Line resistance : max. 100 Ω
Accuracy : ≤ 0.2 %
Zero adjust : Pt100 approx. ± 8 Ω (± 20 °C)
Pt1000 approx. ± 8 Ω (± 2 °C)
End value : adjustable approx. +/-20 %
Sensor error;
- broken or shorted line: output rises to max. output value

Outputs
Current : 0/4..20 mA switch selectable
burden ≤ 1 kΩ
Voltage : 0/2..10 V switch selectable
load max. 15 mA , short-circuit-proof
(simultaneously to the current output
max. 5 mA)
Case : Polycarbonate, UL94V-0
TS 35 acc. to DIN EN 60715:2001-09
Weight : approx. 200 g
Protection class : case IP30, terminals IP20, BGV A3
Electrical connection : screw terminals with pressure plate,
max. 2.5 mm²

Connection diagram

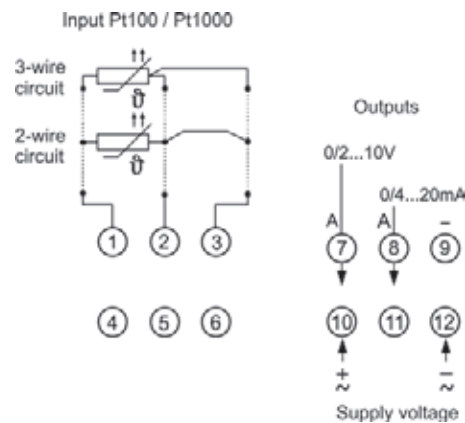

Ordering code

1. 2.
MU500 - -

1. Device type	
51	Pt100, 13 measuring ranges
53	Pt1000, 16 measuring ranges
2. Supply voltage	
0	85..265 V AC
5	10..30 V AC/DC