

Measuring tubes MH-032H



MH-032H040



MH-032H050

Features

Measuring tubes are available for installation of impeller probes of the series RR.-032 in industrial PVC-U pipelines. They can be adhered to the pipeline, for example, with a double sleeve. Measuring tubes with outer diameters 40 mm and 50 mm have a cone on the inlet side for flow conditioning. The measuring result is stabilised in the process. Thus the inlet section can be reduced to 5 times of the inner pipe diameter. The measuring tubes require a tapping clamp BBI-032H-... for installation of the impeller probe (accessory, ordered separately).

Technical data

Wetted material	PVC-U
Compressive strength	PN10

Ordering code

Ordering code	For PVC-U-pipe with outer diameter	Required Tapping clamp
MH-032H040	40 mm	BBI-032H-063
MH-032H050	50 mm	BBI-032H-063
MH-032H063	63 mm	BBI-032H-063
MH-032H075	75 mm	BBI-032H-075
MH-032H090	90 mm	BBI-032H-090
MH-032H110	110 mm	BBI-032H-110
MH-032H125	125 mm	BBI-032H-125
MH-032H140	140 mm	BBI-032H-140
MH-032H160	160 mm	BBI-032H-160

Dimensions

Measuring tube MH-032H040

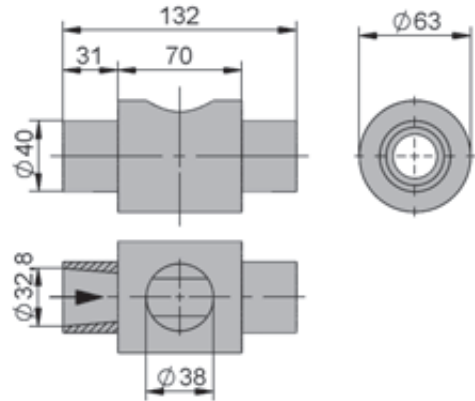

Measuring tube MH-032H050

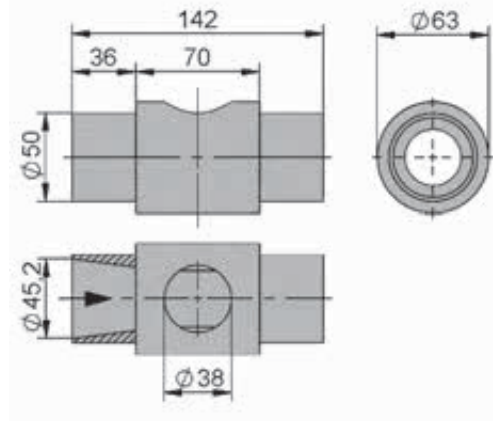

Measuring tube MH-032H...

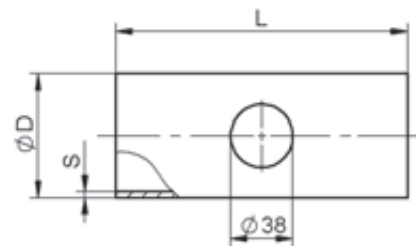

Type	D	S	L
MH-032H063	63	3.0	156
MH-032H075	75	3.6	178
MH-032H090	90	4.3	202
MH-032H110	110	5.3	232
MH-032H125	125	6.0	260
MH-032H140	140	6.7	287
MH-032H160	160	7.7	312