

Flow Meter GK



- Large, easily visible scale
- Set-point indicator
- Optionally switching output

Characteristics

A float moves in a transparent conical measurement tube, relative to the flow. The position of the float depends on the volume flow (weight force versus resistance to flow), and indicates the flow rate on the scaled measurement tube.

Technical data

Switch	optional reed switch	
Nominal width	DN 10.0.25	
Process connection	malleable cast iron, female thread Rp 3/8 " ..Rp 1 " PVC glue socket Ø16..32 (further process connections available on request)	
Metering range	water: 20..640 l/min	for details see table "Ranges"
Q_{max.}	air: 0,02..16 m ³ /h	
	water: to 640 l/min	
	air: to 16 m ³ /h	
Tolerance	±1 % of the full scale value and ±3 % of the measured value	
Pressure resistance	malleable cast iron	PS 15 bar
	PVC	PS 10 bar
Medium temperature	malleable cast iron	-20..+60 °C optionally +5..+100 °C measurement tube made from PSU
	PVC	+5..+60 °C
Ambient temperature	malleable cast iron	-20..+60 °C
	PVC	+5..+60 °C
Media	water, gases	
Electrical data	see "Additional devices for GK / GKL"	

Materials medium-contact	Malleable cast iron connection: PA 6-3-T, malleable cast iron, Viton float made from PP or 1.4571 optionally, measurement tube made from PSU	PVC connection: PA 6-3-T, PVC, Viton float made from PP or 1.4571 optionally, measurement tube made from PSU
Non-medium-contact materials	PA	
Weight	see table "Dimensions and weights"	
Installation location	vertical inwards flow from below	

Ranges

●=Standard ○=Optional

Medium water / float PP

The details in the table correspond to a vertical inwards flow from below.

	Metering range l/h	Magnet		Type
		With out	with	
DN 10 Rp 3/8 "	2 - 25	●		GK-010GTW0025PO
			○	GK-010GTW0025PM
	2 - 40	●		GK-010GTW0040PO
			○	GK-010GTW0040PM
	5 - 60	●		GK-010GTW0060PO
			○	GK-010GTW0060PM
10 - 110	●		GK-010GTW0110PO	
		○	GK-010GTW0100PM	
15 - 160	●		GK-010GTW0160PO	
		○	GK-010GTW0160PM	
DN 15 Rp 1/2 "	20 - 250	●		GK-015GTW0160PO
			○	GK-015GTW0160PM
DN 20 Rp 3/4 "	10 - 160	●		GK-020GTW0160PO
			○	GK-020GTW0160PM
	20 - 250	●		GK-020GTW0250PO
			○	GK-020GTW0250PM
	40 - 400	●		GK-020GTW0400PO
			○	GK-020GTW0400PM
60 - 640	●		GK-020GTW0640PO	
		○	GK-020GTW0640PM	
DN 25 Rp 1 "	20 - 250	●		GK-025GTW0250PO
			○	GK-025GTW0250PM
	40 - 400	●		GK-025GTW0400PO
			○	GK-025GTW0400PM
	60 - 640	●		GK-025GTW0640PO
			○	GK-025GTW0640PM

Medium water / float stainless steel

The details in the table correspond to a vertical inwards flow from below, and increasing flow rate.

	Metering range l/h	Magnet		Type
		with- out	with	
DN 10 Rp 3/8"	4 - 40	○		GK-010.TW0040KO
			○	GK-010.TW0040KM
	5 - 60	○		GK-010.TW0060KO
			○	GK-010.TW0060KM
		○		GK-010.TW0100KO
10 - 100		○	GK-010.TW0100KM	
		○	GK-010.TW0160KO	
DN 15 Rp 1/2"	20 - 160	○		GK-015.TW0160KO
			○	GK-015.TW0160KM
DN 20 Rp 3/4"	20 - 250	○		GK-015.TW0250KO
			○	GK-015.TW0250KM
	30 - 400	○		GK-020.TW0250KO
			○	GK-020.TW0250KM
60 - 600		○	GK-020.TW0400KO	
			GK-020.TW0400KM	
		○	GK-020.TW0600KO	
DN 25 Rp 1"	40 - 400	○		GK-020.TW0600KM
			○	GK-025.TW0400KO
	50 - 650	○		GK-025.TW0400KM
		○	GK-025.TW0650KO	
			GK-025.TW0650KM	

Medium air / float PP

The details in the table correspond to a vertical inwards flow from below, with the medium at a temperature of 0 °C and a pre-pressure of 1.013 bar.

	Metering range m³/h	Magnet		Type
		with- out	with	
DN 10 Rp 3/8"	0.02 - 0.36	○		GK-010.TL0003PO
	0.05 - 0.55	○		GK-010.TL0005PO
	0.10 - 0.90	○		GK-010.TL0009PO
	0.15 - 1.50	○		GK-010.TL0015PO
	0.20 - 2.40	○		GK-010.TL0024PO
DN 15 Rp 1/2"	0.40 - 3.80	○		GK-015.TL0038PO
	0.40 - 4.80	○		GK-015.TL0048PO
DN 20 Rp 3/4"	0.20 - 2.50	○		GK-020.TL0025PO
	0.25 - 3.75	○		GK-020.TL0037PO
	0.50 - 5.50	○		GK-020.TL0055PO
DN 25 Rp 1"	0.75 - 6.50		○	GK-020.TL0065PM
	0.40 - 4.00	○		GK-025.TL0040PO
	0.50 - 6.00	○		GK-025.TL0060PO
		○		GK-025.TL0100PO
1.00 - 10.00			○	GK-025.TL0100PM
	○			GK-025.TL0160PO
	○			GK-025.TL0160PM

Dimensions and weights

Connection malleable, cast iron female thread

Rp	Types	L	L1	G	SW	X	Weight kg
Rp 3/8"	GK-010G..	207	165	G 3/4	32	12	0.2
Rp 1/2"	GK-015G..	215	170	G 1	41	13	0.3
Rp 3/4"	GK-020G..	230	185	G 1 1/4	50	16	0.5
Rp 1"	GK-025G..	250	200	G 1 1/2	55	19	0.7

Connection PVC, glue socket

DN	Types	d	G	L	L1	X	D	Weight kg
10	GK-010M..	16	G 3/4	201	165	12	35	0.1
15	GK-015M..	20	G 1	208	170	13	43	0.2
20	GK-020M..	25	G 1 1/4	229	185	16	53	0.6
25	GK-025M..	32	G 1 1/2	250	200	19	59	0.7

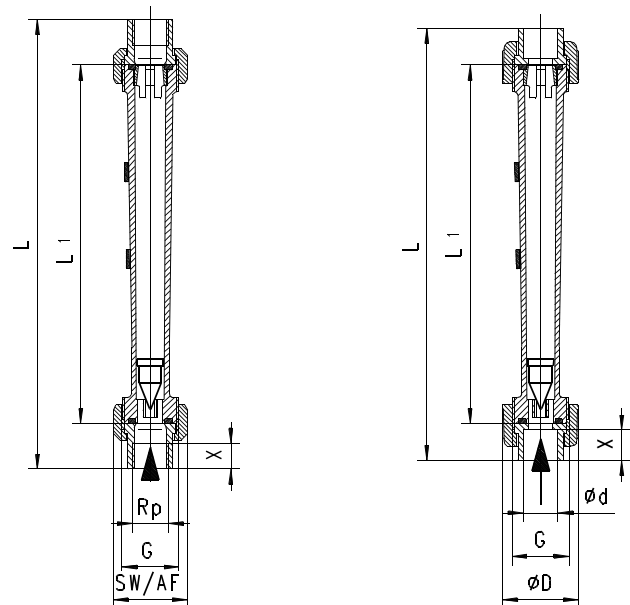

Handling and operation

- Include straight calming section of 5 x DN in inlet and outlet
- If the media are dirty, install a filter (use magnetic filter for ferritic components).
- It must be ensured that the values given for voltage, current, and power are not exceeded.
- When switched on, a load must be connected in series.
- The electrical details apply to ohmic loads. Capacitive, inductive and lamp loads must be operated using a protective circuit.
- Pay attention to the operating temperature/pressure

Connection		Pressure range in bar			
		Maleable cast iron		PVC	
Measurement tube		PA 6-3-T	PSU	PA 6-3-T	PSU
Temperature °C	-20	15.0	-	-	-
	-10	15.0	-	-	-
	0	15.0	-	-	-
	5	15.0	-	10.0	-
	10	15.0	-	10.0	-
	20	15.0	-	10.0	-
	25	15.0	-	10.0	-
	30	13.5	15.0	8.0	-
	40	12.0	13.0	6.0	-
	50	10.7	12.0	3.5	-
	60	9.5	11.0	1.5	-
	70	-	9.7	-	-
	80	-	8.5	-	-
	90	-	7.7	-	-
100	-	6.0	-	-	

Ordering code

GK - 1. 2. 3. 4. 5.

●=Standard ○=Option

1. Nominal width	
010	DN 10 - Rp $\frac{3}{8}$ " or Ø16
015	DN 15 - Rp $\frac{1}{2}$ " or Ø20
020	DN 20 - Rp $\frac{3}{4}$ " or Ø25
025	DN 25 - Rp 1" or Ø32
2. Process connection	
G	female thread, Rp made from malleable cast iron
M	screw connection with glue socket made of PVC
3. Switching current tube	
T	PA 6-3-T
P	PSU
4. Display range H ₂ O for vertical inwards flow	
W0025	2 - 25 l/h ● ○ ●
W0040	2 - 40 l/h ● ○ ●
	4 - 40 l/h ○ ○ ○ ○ ○
W0060	5 - 60 l/h ● ○ ○ ○ ●
W0100	10 - 100 l/h ● ○ ○ ○ ●
W0160	15 - 160 l/h ● ○ ● ●
	● ○ ○ ○ ● ●
W0250	20 - 250 l/h ● ○ ● ●
W0400	40 - 400 l/h ● ○ ○ ○ ● ●
W0600	60 - 600 l/h ○ ○ ○ ○ ○
W0640	60 - 640 l/h ● ○ ● ●
W0650	50 - 650 l/h ○ ○ ○ ○ ○

Display range air (0 °C 1.013 bar abs.) for vertical inwards flow									
L0003	0.02 - 0.36	○							
L0005	0.05 - 0.55	○							
L0009	0.10 - 0.90	○							
L0015	0.15 - 1.50	○							
L0024	0.20 - 2.40	○							
L0025	0.20 - 2.50	○					○		
L0037	0.25 - 3.75	○					○		
L0038	0.40 - 3.80	○					○	○	
L0040	0.40 - 4.00	○					○		
L0048	0.40 - 4.80	○					○	○	
L0055	0.50 - 5.50	○					○		
L0060	0.50 - 6.00	○					○		
L0065	0.75 - 6.50	○					○	○	
L0100	1.00 - 10.00	○ ○					○		
	1.00 - 16.00	○ ○					○		
L0160	1.00 - 16.00	○ ○					○		
	2.00 - 16.00	○ ○					○		

5. Float	
PO	PP
PM	PP with magnet
KO	stainless steel
KM	stainless steel with magnet

Options

- Metering ranges and special scales under defined operating pressures / temperatures

Accessories

- GKEH-1256 / GKEL-1257
- GKEH-1251 / GKEL-1252
- GKK-1271
- GKI-1273

Ordering information

- Specify direction of flow, medium, and display range.
- For gases, state pressure (relative or absolute), temperature and medium (e.g. air) (request display range)